



AIRPLANE TO HEAVEN?

Lesson 28

BIG IDEA

There is not airplane or rocket ship that can take us to heaven. Only the message of the Cross can get us there.

KEY VERSES

John 14:6 and 1 Peter 2:24

MEMORY VERSE

Matthew 4:19-20

“Jesus answered, “I am the way and the truth and the life. No one comes to the Father except through me.

1 Peter 2:24

“He himself bore our sins in his body on the cross, so that we might die to sins and live for righteousness; by his wounds you have been healed.

• PREPARATION & MATERIALS •

BIBLE OBJECT LESSON

- Piece of colored construction paper
- Script

CRAFT

- Experience Mission provides scissors, hole punch, stapler, staples, rulers
- Photo copies of paper airplane guides
- Plenty of white or colored 8.5 x 11 copy paper
- Markers, stickers, glitter glue for decorating
- Paper clips for airplane nose weight (optional)
- Straws (for optional Hoop Glider)
- Tape
- 3 x 5 index cards (for optional Hoop Glider)

GAME

- Extra paper airplanes
- Materials for airplane craft
- Tape
- Paper to label obstacles

WORKSHEETS

- Photocopies of Coloring Sheet (1 per child)



This engaging object lesson should be practiced several times before presenting it to the kids. As an option the script could be reworked so that one team member speaks to the kids while a second team member does the paper folding and tearing.

There is a YouTube video with suggestions on how to make the object lesson go smoothly with maximum impact. YouTube.com "Airplane – Simple Christian Object Lesson" (www.youtube.com/watch?v=XRq1SwDR22o)

- 1) Start by showing the audience the sheet of paper.
- 2) Tell the audience, "I would like to make something out of a sheet of paper. What can we make out of an airplane (someone will likely say a paper airplane)? A paper airplane is fun to make, but I'm going to make a special airplane. Here watch this, normally when making an airplane you would fold it in half. I am going to do something different."
- 3) Fold top left of paper down diagonally.
- 4) Say to your audience, "Now we will make a fold the other way."
- 5) Follow the diagram below. Fold the sheet from point C to point D.



- 6) Say to your listeners, "Now we will fold our airplane in half."

- 7) Fold the paper in half.

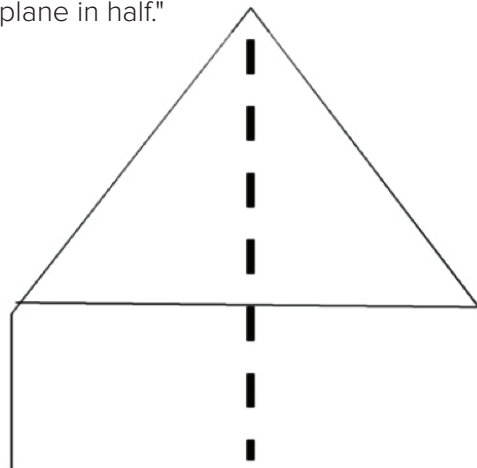

8) Next you say, "We want to give our airplane some wings."

9) Make the wings fairly large. You do not want more than one inch for the base of the airplane. You will notice a little triangle in the center of the airplane. Leave the triangle sticking straight up.

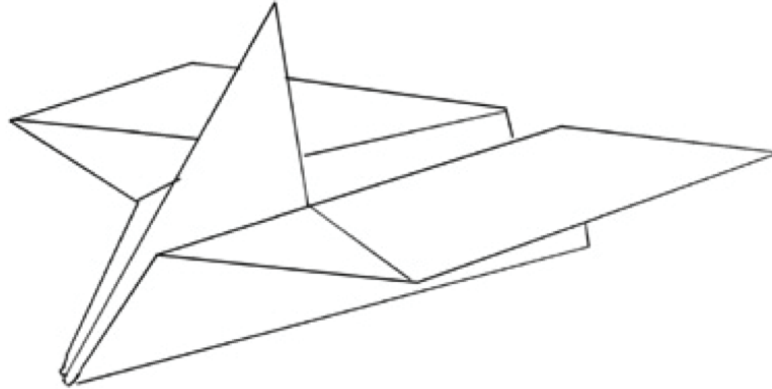

10) "See we have a pretty awesome paper airplane. Who can tell me how far you throw a paper airplane? Not too far, maybe 50 feet if we are lucky. How high can you fly in a real airplane? Well you can fly maybe 20 miles high and you can fly around the world. Can you fly up to Heaven in an airplane? Of course not! You can't fly up to Heaven in an airplane. Let's make something different. Let's tear off this little triangle."

11) Tear off the triangle. Remember to tear it off at the point that the triangle meets the wings. Don't tear any lower.

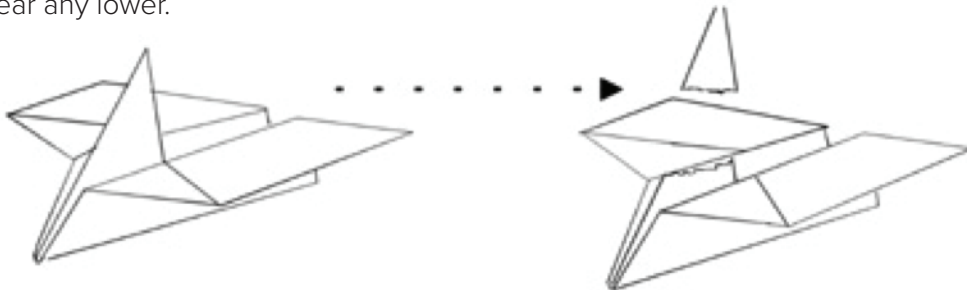

12) "Let's get rid of the wings."

13) Tear off the wings at the point where they are folded. At the bottom of the wings you will need to tear a diagonal fold. This will leave you with something that looks like a rocket ship.

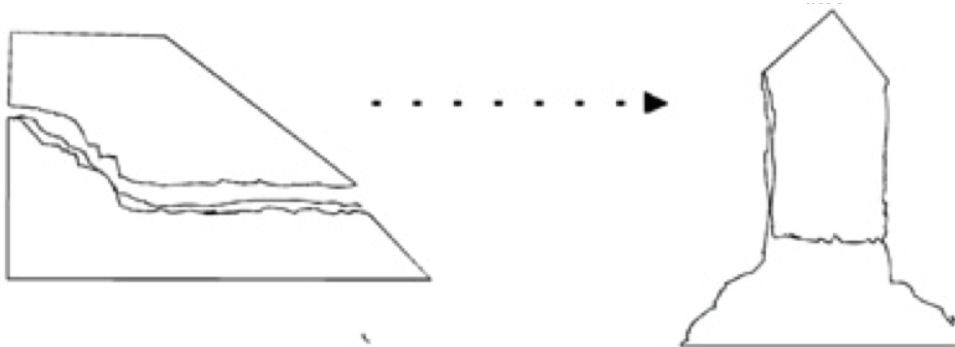

14) "Now we have a rocket ship. How high can you go in a rocket ship? You can go all the way into outer space. Tell me can you fly all the way up to Heaven in a rocket ship? Of course not. The Bible tells us that there is nothing we can do on our own, without Christ to get to Heaven. We can build a plane or a rocket ship, but we can't fly up to Heaven. We can go to church, or be good person, but that will not get us to Heaven. That is why Jesus came down to earth. To die on the cross for our sins. Jesus came to give us the one way to get to Heaven. That is the way of the cross."

15) Unfold to reveal the cross

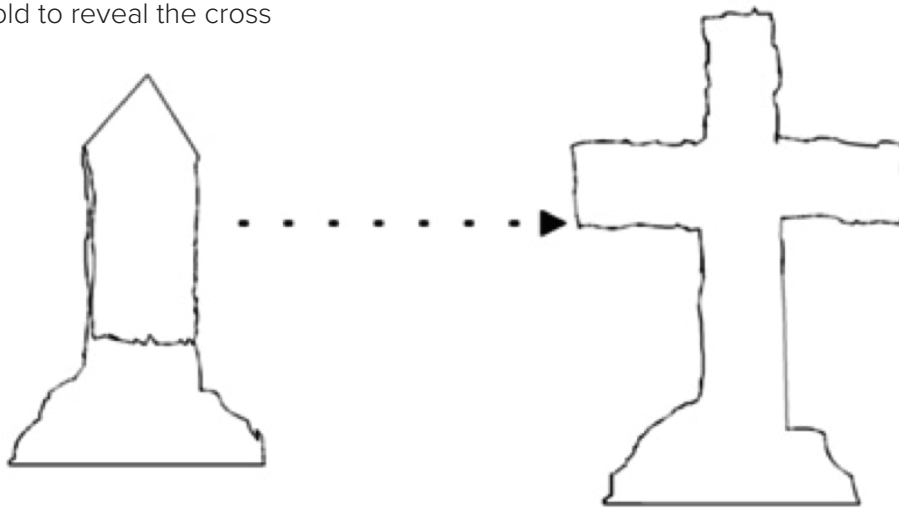

SIMPLIFIED LESSON OPTIONS

- *Tell the story of Jesus' birth, ministry, death and resurrection in simple story form.*
- *Read the gospel story (next page)*



AIRPLANE TO HEAVEN?

BIBLE OBJECT LESSON

Lesson 28

THE GOSPEL STORY

God created everything that exists--the universe, the world and nature. He also created man. God made the first man and woman, Adam and Eve, absolutely perfect--just as He is. Genesis 1:26-27.

God told Adam not to eat of the fruit of the tree in the middle of the garden. But Adam and Eve disobeyed God and ate the fruit, and sin entered the world. Genesis 2:17, Genesis 3:6-7, Isaiah 59:2.

God sent Jesus to earth. Jesus was born as a baby on earth. When Jesus was a man He went around telling people about God and doing good. Jesus showed us God's love. John 3:16, Luke 2:4-7, Matthew 9:35.

Jesus was crucified. There were bad, jealous men that hated Jesus so much that they nailed Him to a cross. Yet this was God's plan - the only way for Him to get rid of sin. A sinless person had to take the blame and the punishment for the worlds sin. Only Jesus could. Mark 15:25-39, Isaiah 53:6, 1 Peter 3:18.

A stone was rolled across the entrance of the tomb. The tomb was sealed and Roman guards were put there. Matthew 27:59-60, Matthew 27:65-66.

Jesus rose from the dead. On the third day God raised Jesus from the dead. The stone was rolled away. Matthew 28:1-7

Jesus returned to heaven. Jesus spoke to His disciples and told them to spread the Good News. Then He lifted up into heaven where He sits on the right side of His Father. John 20:20, Acts 1:8-11, Colossians 3:1.

Jesus can take away our sin and give us eternal life. If you ask Jesus to forgive you and make your heart new, He will come and live in you and give you eternal life. 1 John 1:9, John 6:47, Romans 6:22.

Jesus will come back in the clouds and he will take us to heaven to be with him.



AIRPLANE TO HEAVEN?

CRAFT

Lesson 28

• CRAFT •

OBJECTIVE: PAPER AIRPLANES

Fold and decorate several different types of paper airplane.

MATERIALS PROVIDED BY EM

- Scissors, staplers, rulers, hole punches

DIRECTIONS

- See airplane folding guides and instructions in the following pages.
- Optional Hoop Glider
 1. Cut index card into 3 pieces measuring 1 x 5"
 2. Tape two pieces together (overlap ends) to create a long strip
 3. Tape long strip together to create a large circle
 4. Tape small strip together to create small circle
 5. Tape the small circle to one end of the straw
 6. Tape the large circle to the other end of the straw
 7. Hold in the middle and throw!

MATERIALS BROUGHT BY TEAM

- Photo copies of paper airplane guides
- Plenty of white or colored 8.5 x 11 copy paper
- Markers, stickers, glitter glue for decorating
- Paper clips for airplane nose weight (optional)
- Straws (for optional Hoop Glider)
- Tape
- 3 x 5 index cards (for optional Hoop Glider)

EXAMPLE

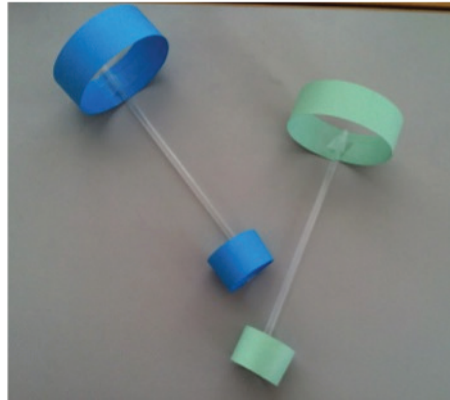

SIMPLIFIED CRAFT OPTIONS

- Pre-cut index cards into 1x5 inch strips
- Pre-tape two strips to form 1x9 inch strips
- Use colored card stock and cut multiple 1x5 and 1x9 inch strips on a paper cutter.



AIRPLANE TO HEAVEN?

GAME

Lesson 28

• GAME •

OBJECTIVE: AIRPLANE OBSTACLE COURSE

Use the airplanes made during craft time to race through an obstacle course.

INSTRUCTIONS

- Set up an obstacle course by numbering various objects in the play area (ie. Tree, side of building, large rock, patch of dirt, shrub, etc)
- Let the kids “fly” through the obstacle course with their paper airplanes
- Options: set up a time limit, create teams, establish a goal such as running the course in less than 20 throws, etc.

MATERIALS BROUGHT BY TEAM

- Extra paper airplanes
- Airplanes made during craft time (see craft instructions)
- Tape
- Paper to label obstacles



the cross

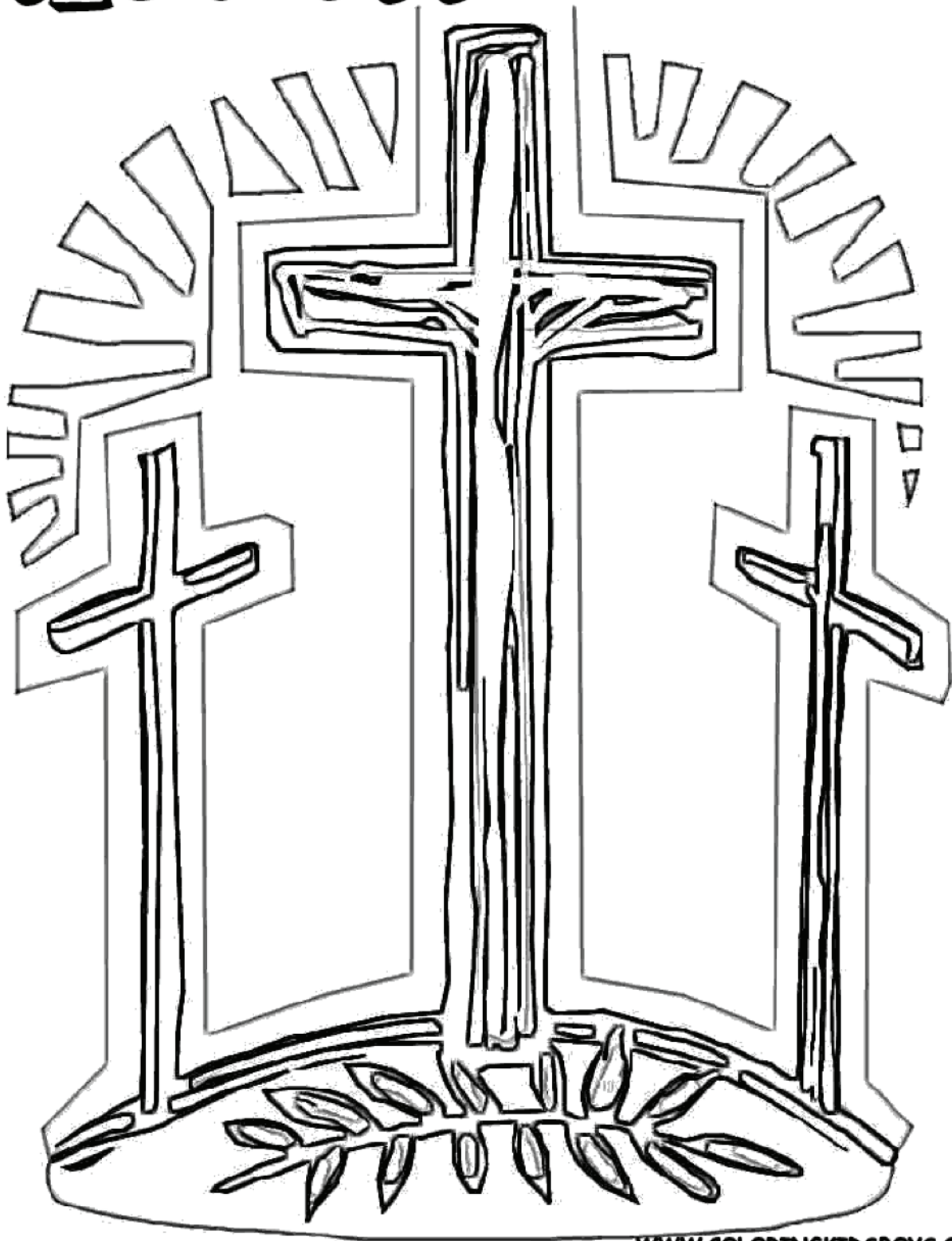

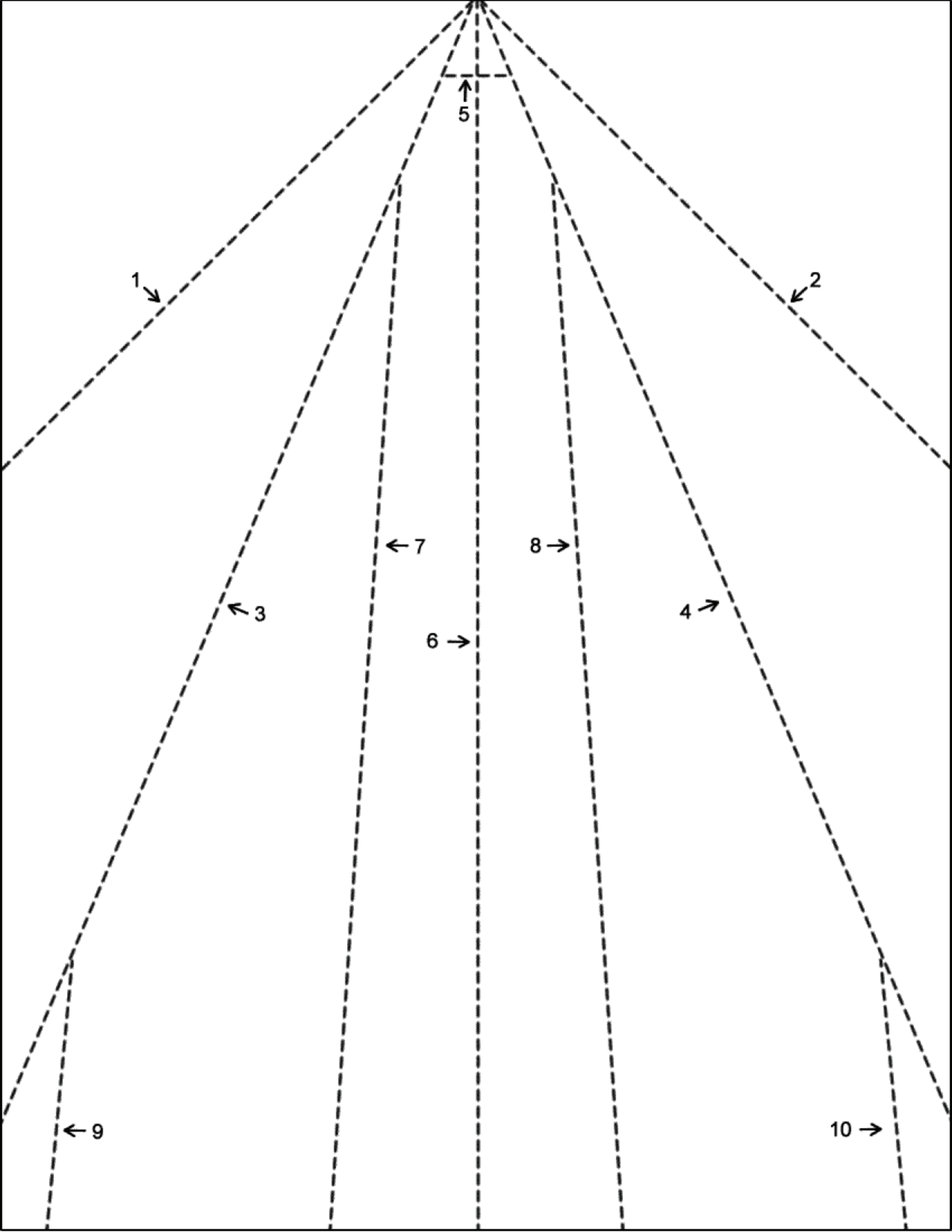

Lesson 28
AIRPLANE TO HEAVEN?

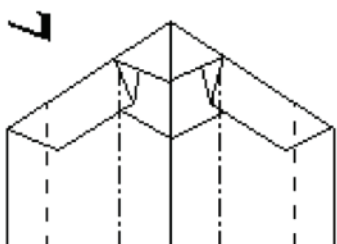
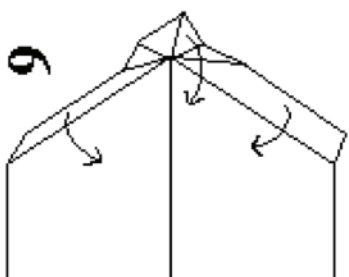
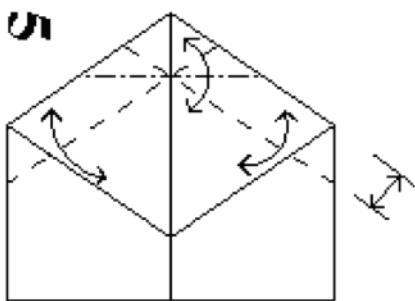
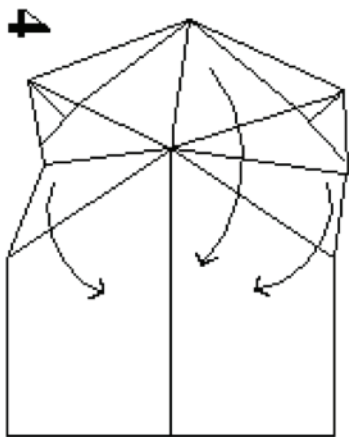
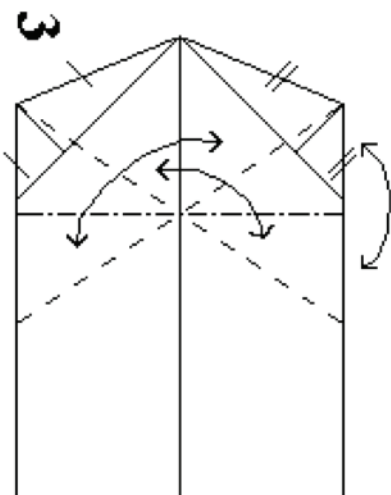
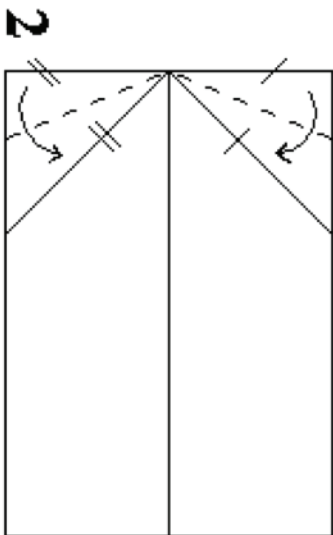
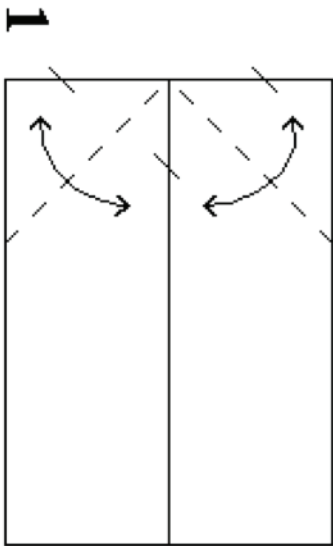



AIRPLANE TO HEAVEN?

lesson 28

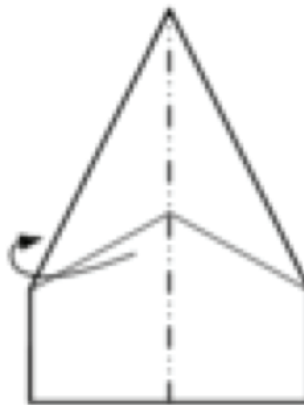
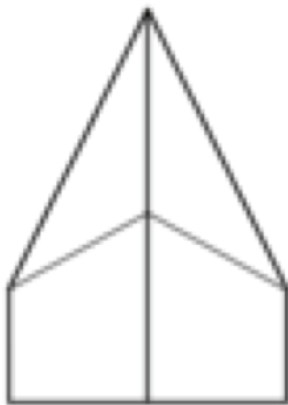
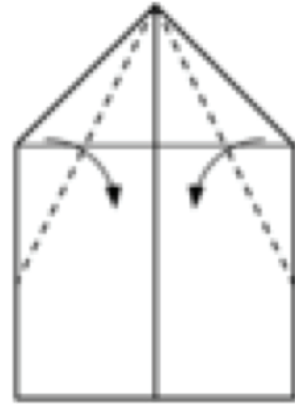
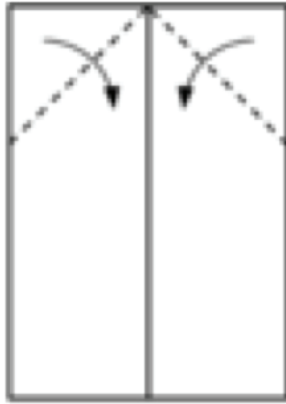
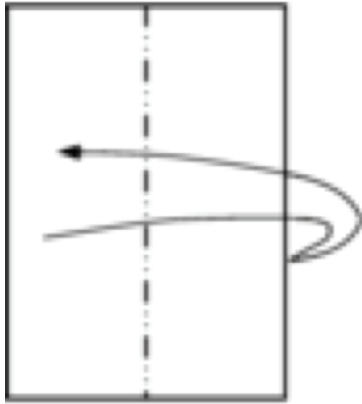

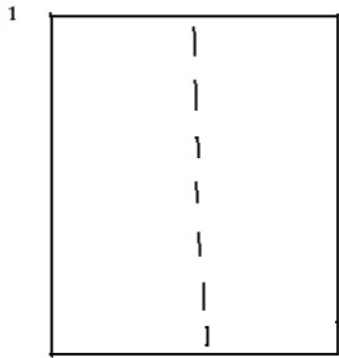

unfold again

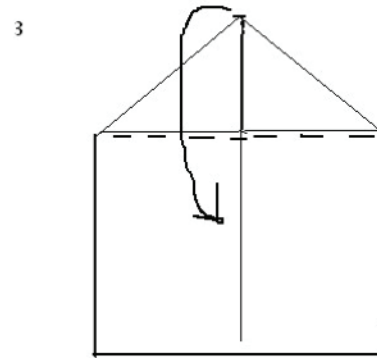
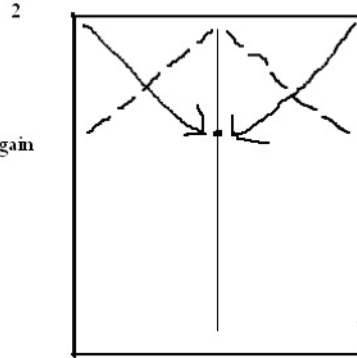

--- = Fold

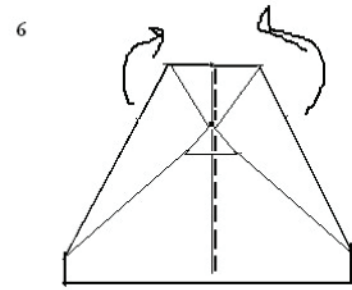
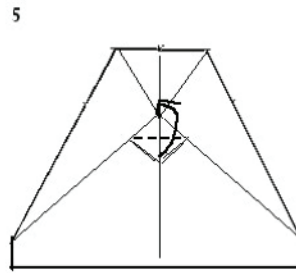
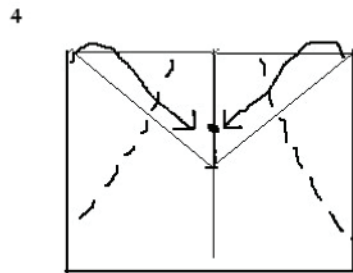

Do step 7 to both wings on both sides.



Now simply elevate the wings and you are done! -Be sure to make the wings angles slightly upwards then just straight at a 90 degree angle. It'll fly better. ;)